

MST SERIES TESTERS

10 LB TO 500 LB CAPACITY MANUAL TESTERS

SPECIFICATIONS*

- Accuracy: $\pm 0.4\%$ of full scale capacity on 500 division graduated dial.
- Actuating force: 10 lb at full capacity.
- Drive mechanism: Manual hand wheel, rack and pinion drive with self-locking clutch. Travels $\frac{3}{8}$ inch (9 mm) per revolution of hand wheel.
- Maximum stroke: 9 inches (228 mm).
- Horizontal clearance between columns: 7- $\frac{1}{4}$ inches (184 mm).
- Compression testing:
 - Maximum vertical clearance: 12 inches (304 mm).
 - Minimum vertical compression: 3 inches (76 mm).
 - Maximum spring size, outer diameter: 4- $\frac{7}{8}$ inches (123 mm).
 - Minimum spring size, inner diameter: 5- $\frac{1}{16}$ inches (8 mm).
- Tension testing:
 - Maximum extended length at full load: 8- $\frac{3}{4}$ inches (222 mm).
 - Minimum extended length: 1- $\frac{3}{8}$ inches (35 mm).
 - Maximum spring size, outer diameter: 4- $\frac{1}{8}$ inches (105 mm).

WEIGHT

Instrument: 100 lbs. (45 kg)

Shipping: 130 lbs. (59 kg)

MST SERIES CAPACITY RATINGS

MODEL	CAPACITY	X	GRADUATION
MST-10	10 lb	x	0.02 lb
MST-25	25 lb	x	0.05 lb
MST-50	50 lb	x	0.10 lb
MST-100	100 lb	x	0.20 lb
MST-250	250 lb	x	0.50 lb
MST-500	500 lb	x	1.00 lb

DIMENSIONS

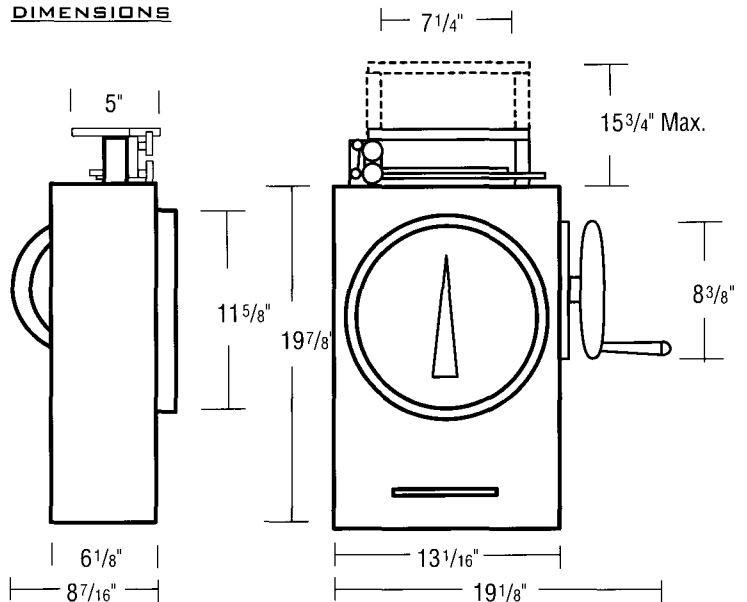

STANDARD ACCESSORIES

- Upper and lower compression plates (carriage platens).
- Two clevis grips for extension testing.
- $\frac{1}{4}$ " diameter core rod for compression testing small springs.
- 12" stainless steel deflection measurement ruler.
- Dual magnifier with pointers.
- Bracket for standard dial indicator.
- Instruction manual.

OPTIONAL ACCESSORIES

- Maximum reading pointer.
- 1 inch (25 mm) measurement dial indicator.
- Grips available for a wide range of needs.

Since 1835, Chatillon has set the standard for quality, reliability and value in weighing scales and force measuring instruments. We offer the broadest range of gauges, test stands and testing systems available from a single source, with products recognized worldwide for their superior craftsmanship and rugged reliability.

FOR MORE INFORMATION ON OUR COMPLETE LINE OF
FORCE TESTING GAUGES, STANDS, GRIPS AND ACCESSORIES,
CALL US AT (800) 527-9999
OR VISIT [HTTP://WWW.CHATILLON.COM](http://www.chatillon.com)

AMETEK® Chatillon®

*Chatillon reserves the right to modify these specifications without prior notification. Copyright 1997 John Chatillon & Sons, Inc. All rights reserved.